

**SRC/SRX | SETUP & SERVICE MANUAL**



## SUNRINGLE

5800 W Donges Bay Rd  
Mequon, WI 53092

[sun-ringle.com](http://sun-ringle.com)

888.686.3472

Support: [sun-ringle.com/support](http://sun-ringle.com/support)

## WARRANTY

For full warranty information please visit [hayesbicycle.com/warranty](http://hayesbicycle.com/warranty)

# INTRODUCTION

This manual is intended to provide the information necessary to service the following hubs:

- SUNringle SRC
- SUNringle SRX
- SUNringle ATAC (Cube)
- Reynold's by Ringle
- Pivot branded hubs assembled with SUNringle rims

### ⚠ WARNING ⚠

We highly recommend service to be performed by a qualified mechanic. These instructions can be downloaded from the Hayes Bicycle website at: [hayesbicycle.com/support](http://hayesbicycle.com/support)

We highly recommend that service to this hub be performed by a certified bicycle mechanic. Failure to follow instructions presented in this manual could lead to serious injury or death. Any questions about the servicing of product or the manual itself should be directed to Hayes Customer Support at:

<b>Hayes Bicycle USA</b>	5800 W Donges Bay Road Mequon WI 53092
	Phone: 888.686.3472
	Email: <a href="mailto:techsupport@hayesbicycle.com">techsupport@hayesbicycle.com</a>

<b>Hayes Bicycle Europe</b>	Dirnismaning 20 a 85748 Garching (b. Munich) Germany
	Phone: +49 89 203237450
	Email: <a href="mailto:techsupportEU@hayesbicycle.com">techsupportEU@hayesbicycle.com</a>

<b>Hayes Bicycle Asia</b>	16F, No. 37, Sec. 3 Mincyuan E. Rd. Zhongshan District Taipei City 10476 Taiwan ROC
	Phone: 886-2-2518-1108

HAYES

**M**  
manitou

**PROTAPER**

**REYNOLDS**

**SUN**  
ringle

WHEELSMITH  
**W**  
SPOKES

**HAYES**  
PERFORMANCE SYSTEMS

HAYES

**M**  
manitou

**PROTAPER**

**REYNOLDS**

**SUN**  
ringle

WHEELSMITH  
**W**  
SPOKES

SETUP & SERVICE MANUAL

3

# TABLE OF CONTENTS

SECTION	PAGE NUMBER
<a href="#">Tools And Materials</a>	5
<a href="#">Hub Disassembly</a>	6-7
<a href="#">Freehub Disassembly</a>	8-9
<a href="#">Freehub Assembly</a>	9-12
<a href="#">Hub Rebuild</a>	13-15
<a href="#">Exploded Views</a>	16-23

# TOOLS AND MATERIALS

Below is a list of tools and materials necessary for servicing SRC and SRX hubs.

- SUNringlé Axle Tool – Part # BSHUBTOOL
- SUNringlé 30T Ratchet Ring Tool – Part # 281-33222-K001
- 17mm Cone Wrench (For 12mm hub axles)
- 5mm Allen Wrench (For QR hub axles)
- Rubberized Dead Blow Hammer
- 90 Degree Pick Tool
- Snap Ring Pliers
- Bench Mounted Vice
- High quality bicycle grease
- Freehub Body grease (Dumonde Tech Freehub Body Grease recommended)
- Freehub Body oil (Dumonde Tech Freehub Body Oil recommended)
- Bearing puller OR hammer and punch
- Bearing press
- Lint Free rag

# HUB DISASSEMBLY

**1** Remove the wheel from the frame, remove cassette and rotor. Remove the non-drive side end cap by pulling it straight off the axle.

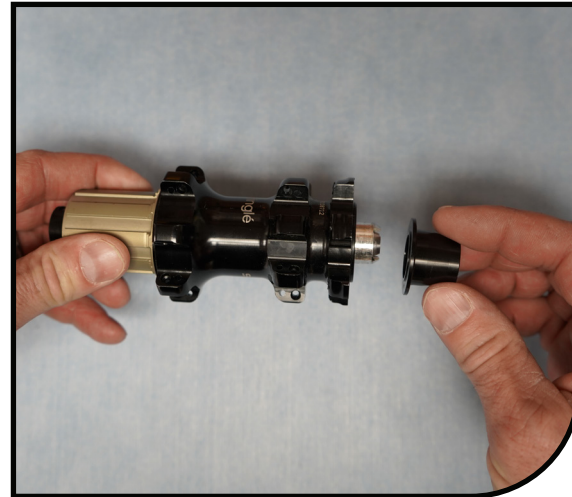

**2** Place the BSHUBTOOL in the end of the non-drive side axle.



**3** Place the 17mm cone wrench (12mm axle) or 5mm Allen wrench (QR axle) on the drive side end cap and loosen the end cap by turning the wrench counterclockwise while holding the BSHUBTOOL still. Remove the end cap.

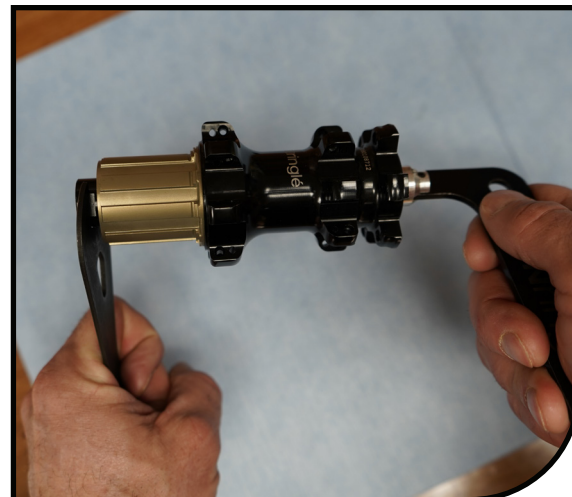

# HUB DISASSEMBLY

**4** Slide the Freehub Body by gently pulling it away from the hub shell.

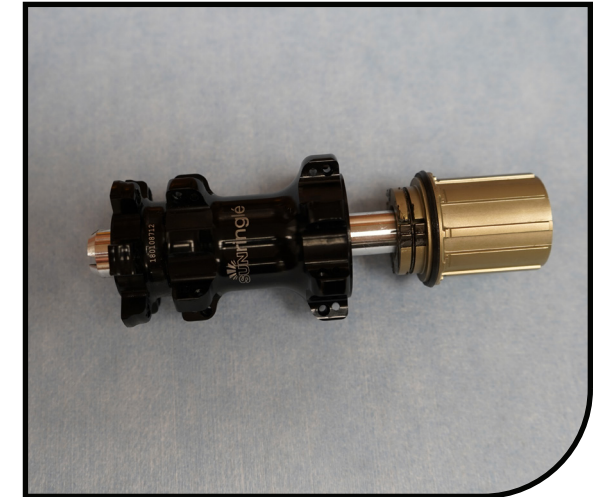

**5** Remove the non-drive bearing and axle from the hub shell by hitting the drive side end of the axle with the dead blow hammer.

**NOTE:** To avoid damaging the axle, reinstall the drive side end cap finger tight and hit the end of the end cap.



**6** Remove the drive side bearing by using a bearing puller or hammer and punch. Remove the ratchet ring by installing the ratchet ring tool Part # 281-33222-K001 into a bench mounted vice. Place the wheel over the ratchet ring tool and spin the wheel counterclockwise to remove the ratchet ring.

**NOTE:** The ratchet ring can only be removed when in a complete wheel.

**NOTE:** For basic service the ratchet ring does not need to be removed.





# FREE HUB DISASSEMBLY

**1** Using the 90-degree pick tool, remove the wire spring by stretching in outwards and removing the spring from the freehub body.



**2** Remove the pawls from the pawl pockets.

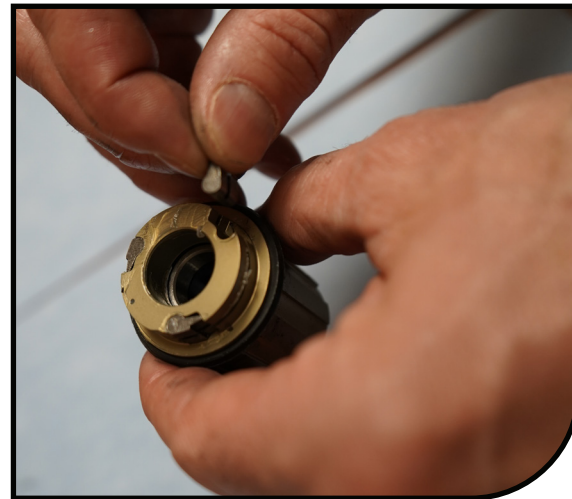

**3** Remove the seal from the drive side of the freehub body.



# FREE HUB DISASSEMBLY

**4** For Shimano HG freehub body, remove the snap ring holding in the outboard bearing. For XD or MicroSpline, skip to step 5.



**5** Remove the bearings forcing them outward of the freehub body.

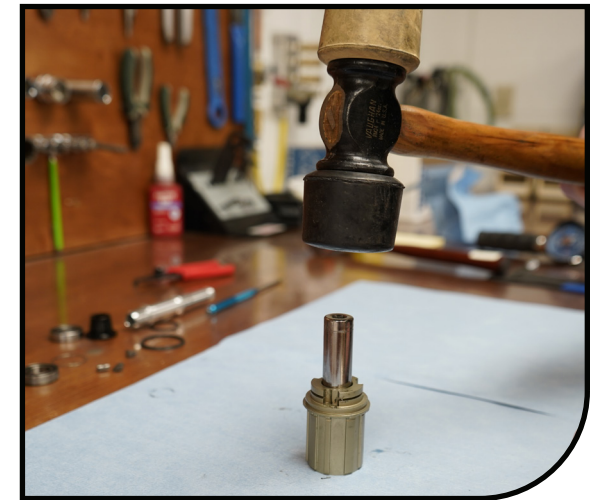

# FREE HUB ASSEMBLY

- 1 Lightly grease the new bearing with high quality bicycle grease. Press in the in-board bearing.



- 2 Install the spacer, lightly grease and press in the out-board bearing.

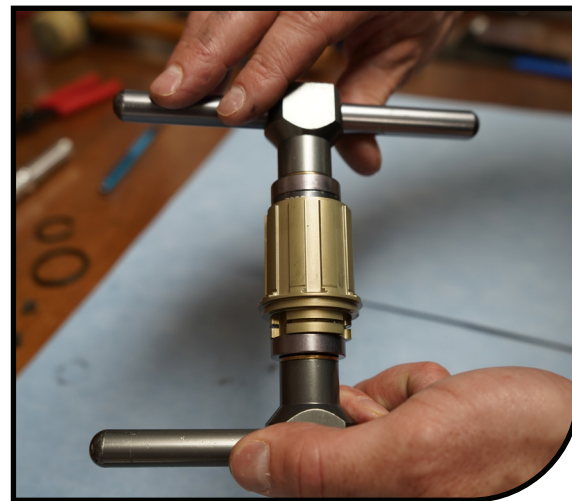

- 3 For Shimano HG freehub body, install the snap ring. For XD or MicroSpline, skip this step.



# FREE HUB ASSEMBLY

- 4 Install the wire spring by hooking it into the retention hole and wrapping the spring back into the groove.



- 5 Install the pawls by slipping them between the spring and the pawl pocket making sure the spring is in the pawl groove.



- 6 Install the seal onto the freehub body.

**NOTE:** The lip must face out towards the cassette.





## FREEHUB ASSEMBLY

- 7 Lubricate the pawls and spring with freehub body grease for quieter operation and longer service life. Use freehub oil for louder operation and improved low temperature operation.



- 8 Lightly lubricate seal with freehub oil.



## HUB REBUILD

- 1 Thread the ratchet ring into the hub shell with the machining groove facing you. The ratchet ring only needs to be hand tight. It will tighten 100% during your pedal stroke.



- 2 Lightly grease the new bearings. Press the NDS bearing in first, making sure that it is fully seated in the hub shell. Slide the axle into place and then install the DS bearing. Rotate the axle to make sure it rotates smoothly and that there is no side to side movement.



- 3 Lubricate the ratchet ring with freehub body grease for quieter operation and longer service life. Use freehub oil for louder operation and improved low temperature operation.

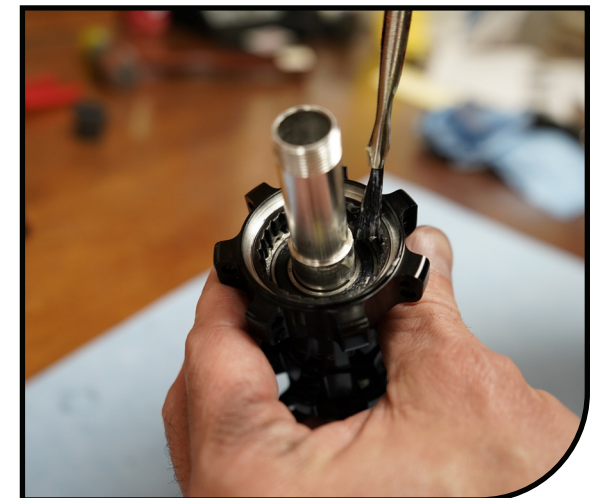

## HUBREBUILD

- 4** Slide the freehub body onto the axle, rotating it counterclockwise as you do so to collapse the pawls allowing them to pass into the hub shell cavity and align into the ratchet ring.



- 5** Thread the drive side endcap onto the axle.



- 6** Insert BSHUBTOOL into the non-drive side of the axle and use the 17mm cone wrench (12mm axle) or 5mm Allen wrench (QR axle) to tighten the drive side end cap to 17.70 in lbs (2 Nm).



## HUBREBUILD

- 7** Push the non-drive side end cap over the axle.

Reinstall the cassette and rotor.





# SRC/SRX FRONT 6 BOLT EXPLODED VIEW

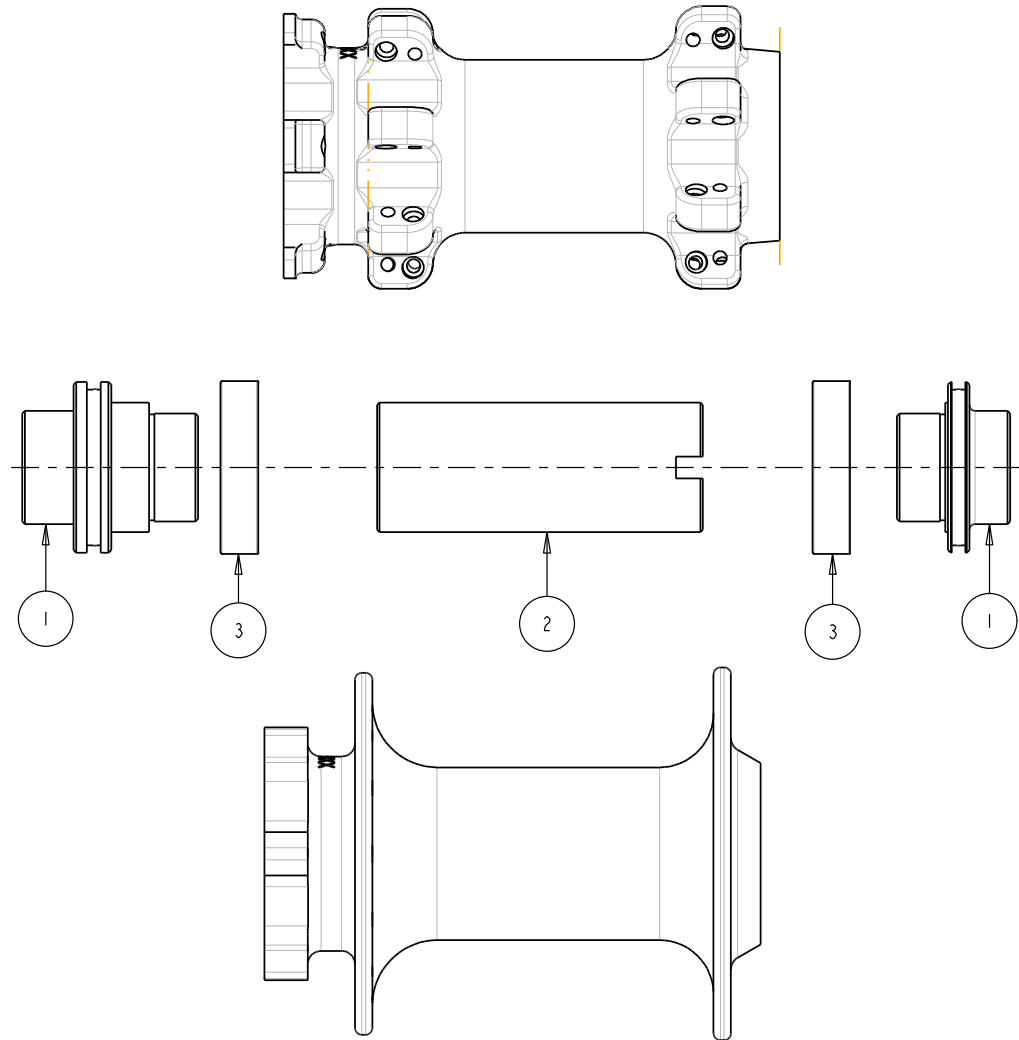

	Description	Part #
1	SRC/SRX Front Hub QR End Cap Kit	281-31519-K001
	SRC/SRX Front Hub 15mm End Cap Kit	281-31519-K002
	SRC/SRX Front Hub 20mm End Cap Kit	281-31519-K003
	SRC/SRX Front 12mm End Cap Kit	281-31519-K009
	SRC/SRX Front 15mm Torque End Cap Kit	281-31519-K011
	SRC/SRX Front Boost 20mm End Cap	281-31519-K012
2	SRC/SRX Front Hub Spacer Tube Kit 100mm	281-32015
	SRC/SRX Front Hub Spacer Tube Kit 110mm	281-32015-K002
	SRC/SRX Front Hub Spacer Tube Kit 150mm (SRC Only)	281-32015-K003
3	SRC/SRX 6804 Bearing (32x20x7) Kit Qty 2	281-32016

# SRX-CL FRONT EXPLODED VIEW

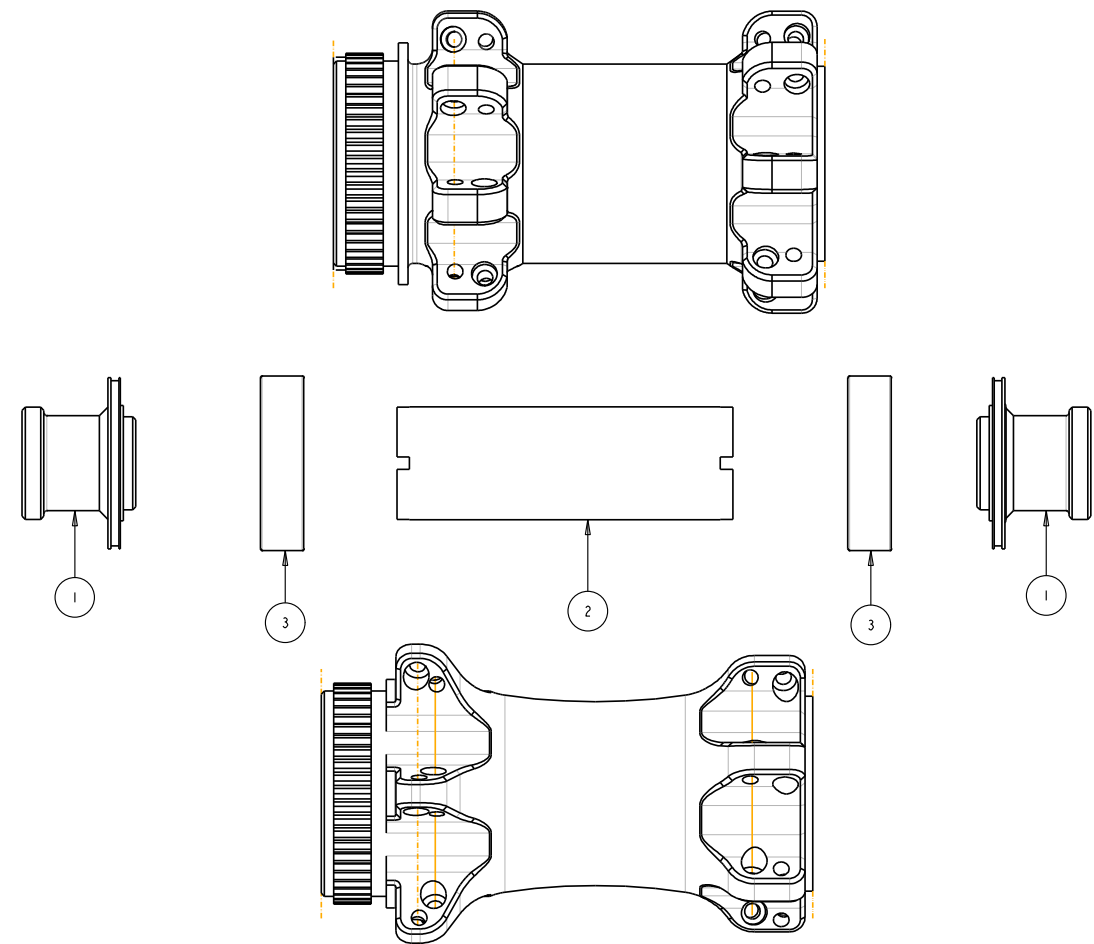

	Description	Part #
1	SRX CL Front QR End Cap Kit	281-31519-K019
	SRX CL Front 12mm End Cap Kit	281-31519-K018
	SRX CL Front 15mm End Cap Kit	281-31519-K017
2	SRX CL Front Hub Spacer Tube Kit - 100mm	281-32015-K005
	SRX CL Front Hub Spacer Tube Kit - 110mm	281-32015-K004
3	SRC/SRX 6902 Bearing( 28x15x7) Kit Qty 2	281-32011

# SRCREAR 6 BOLT EXPLODED VIEW

	Description	Part #
1	SRC/SRX FH Body Kit HG Steel 3 Pawl	281-31520-K001
	SRC/SRX FH Body Kit HG Alloy 3 Pawl	281-31520-K002
	SRC/SRX FH Body Kit XD Steel 3 Pawl	281-31520-K003
	SRC/SRX FH Body Kit XD Alloy 3 Pawl	281-31520-K004
	SRC/SRX FH Body Kit HG 11R Alloy 3 Pawl	281-31520-K006
	SRC/SRX FH Body Kit MS Alloy 3 Pawl	281-31520-K007
	SRC/SRX FH Body Kit MS Steel 3 Pawl	281-31520-K008
	SRC/SRX FH Body Kit XDR Alloy 3 Pawl	281-31520-K013
	SRC/SRX FH Body kit Campy N3W Al 3 pawl	281-31520-K016
2	SRC/SRX Rear Hub QR HG End Cap Kit	281-31519-K004
	SRC/SRX Rear Hub 12mm HG End Cap Kit	281-31519-K005
	SRC/SRX Rear Hub QR XD End Cap Kit	281-31519-K006
	SRC/SRX Rear Hub 12mm XD End Cap Kit	281-31519-K007
	SRC/SRX Rear Hub 135/150 HG End Cap Kit	281-31519-K008
	SRC/SRX Rear Hub 135/150 XD End Cap Kit	281-31519-K010
	SRC/SRX Rear 12mm MS End Cap Kit	281-31519-K013
	SRC/SRX Rear QR MS End Cap Kit	281-31519-K022
	SRC/SRX Rear 12mm Campy N3W End Cap Kit	281-31519-K024
3	SRC/SRX Ratchet Ring Kit	281-32014
4	SRC/SRX Pawl/Spring Kit 3 Pawl	281-31620
5	SRC/SRX Rear Axle 135/142 Kit - Alloy	281-32013
	SRC/SRX Rear Axle 148 Kit - Alloy	281-32013-K002
	SRC/SRX Rear Axle 150/157 Kit - Alloy	281-32013-K003
	SRC Rear Axle 170/177 Kit - Alloy	281-32013-K004
	SRC Rear Axle 190/197 Kit - Alloy	281-32013-K005
	SRC/SRX Rear Axle 135/142 Kit - Steel	281-32013-K006
	SRC/SRX Rear Axle 148 Kit - Steel	281-32013-K007
	SRC/SRX Rear Axle 150/157 Kit - Steel	281-32013-K008
	SRC Rear Axle 170/177 Kit - Steel	281-32013-K009
	SRC Rear Axle 190/197 Kit - Steel	281-32013-K010
6	SRC/SRX 6903 Bearing (30x17x7) Kit Qty 2	281-32012
7	SRC/SRX 6902 Bearing (28x15x7) Kit Qty 2	281-32011
8	SRC/SRX 63802 Bearing (24x15x7) Kit Qty 3	281-38402

# SRCREAR 6 BOLT EXPLODED VIEW

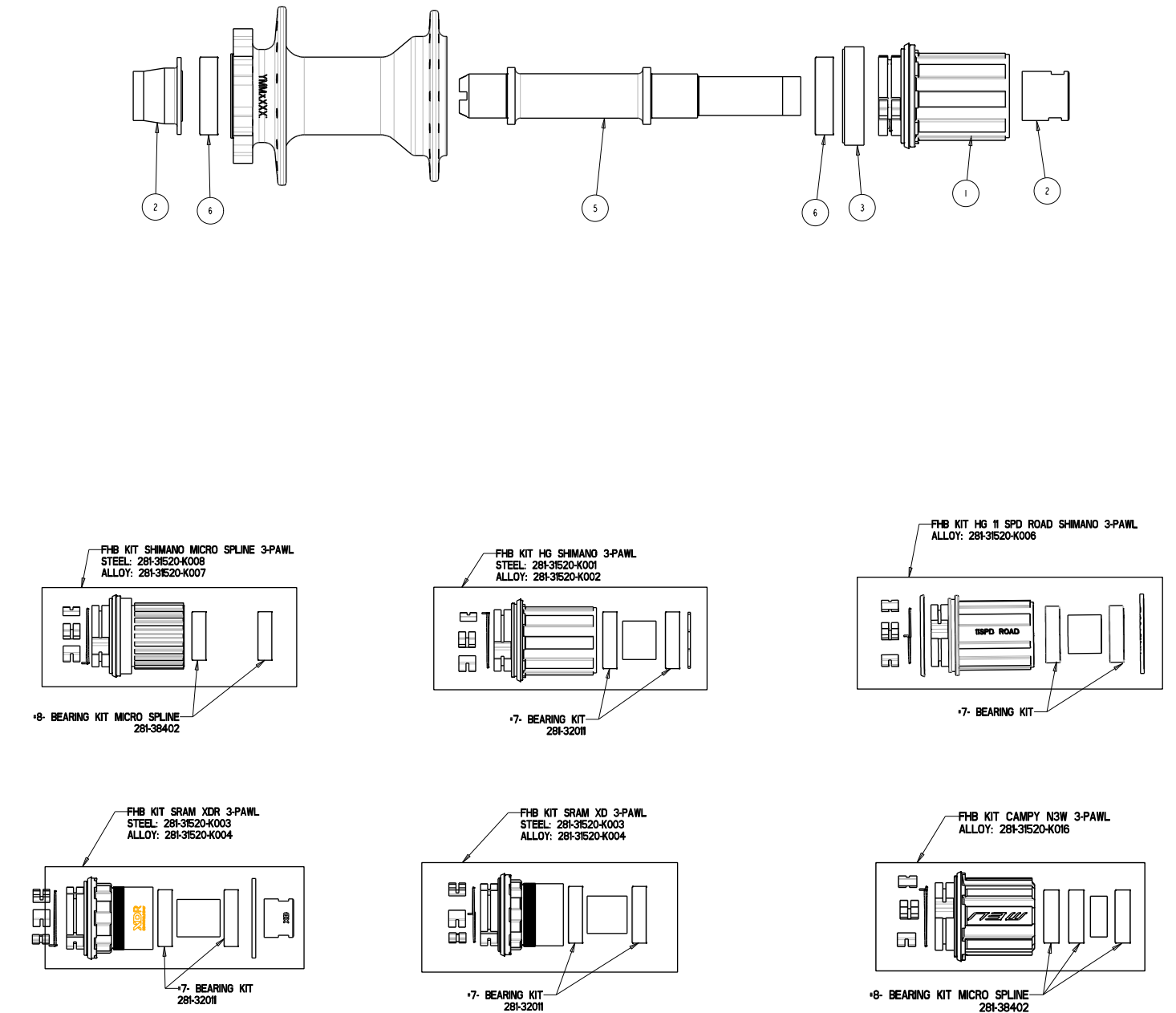

# SRX REAR 6 BOLT EXPLODED VIEW

	Description	Part #
1	SRC/SRX FH Body Kit HG Steel 3 Pawl	281-31520-K001
	SRC/SRX FH Body Kit HG Alloy 3 Pawl	281-31520-K002
	SRC/SRX FH Body Kit XD Steel 3 Pawl	281-31520-K003
	SRC/SRX FH Body Kit XD Alloy 3 Pawl	281-31520-K004
	SRC/SRX FH Body Kit HG 11R Alloy 3 Pawl	281-31520-K006
	SRC/SRX FH Body Kit MS Alloy 3 Pawl	281-31520-K007
	SRC/SRX FH Body Kit MS Steel 3 Pawl	281-31520-K008
	SRC/SRX FH Body Kit XDR Alloy 3 Pawl	281-31520-K013
	SRC/SRX FH Body kit Campy N3W Al 3 pawl	281-31520-K016
2	SRC/SRX Rear Hub QR HG End Cap Kit	281-31519-K004
	SRC/SRX Rear Hub 12mm HG End Cap Kit	281-31519-K005
	SRC/SRX Rear Hub QR XD End Cap Kit	281-31519-K006
	SRC/SRX Rear Hub 12mm XD End Cap Kit	281-31519-K007
	SRC/SRX Rear Hub 135/150 HG End Cap Kit	281-31519-K008
	SRC/SRX Rear Hub 135/150 XD End Cap Kit	281-31519-K010
	SRC/SRX Rear 12mm MS End Cap Kit	281-31519-K013
	SRC/SRX Rear QR MS End Cap Kit	281-31519-K022
SRC/SRX Rear 12mm Campy N3W End Cap Kit	281-31519-K024	
3	SRC/SRX Ratchet Ring Kit	281-32014
4	SRC/SRX Pawl/Spring Kit 3 Pawl	281-31620
5	SRC/SRX Rear Axle 135/142 Kit - Alloy	281-32013
	SRC/SRX Rear Axle 148 Kit - Alloy	281-32013-K002
	SRC/SRX Rear Axle 150/157 Kit - Alloy	281-32013-K003
	SRC/SRX Rear Axle 135/142 Kit - Steel	281-32013-K006
	SRC/SRX Rear Axle 148 Kit - Steel	281-32013-K007
SRC/SRX Rear Axle 150/157 Kit - Steel	281-32013-K008	
6	SRC/SRX 6903 Bearing (30x17x7) Kit Qty 2	281-32012
7	SRC/SRX 6902 Bearing (28x15x7) Kit Qty 2	281-32011
8	SRC/SRX 63802 Bearing (24x15x7) Kit Qty 3	281-38402

# SRX REAR 6 BOLT EXPLODED VIEW

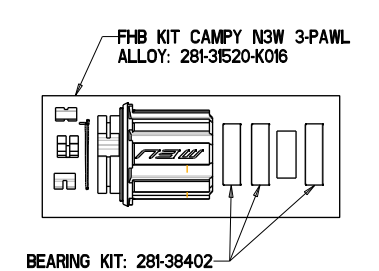
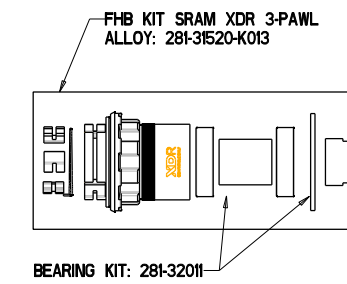
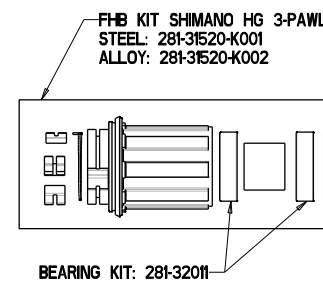
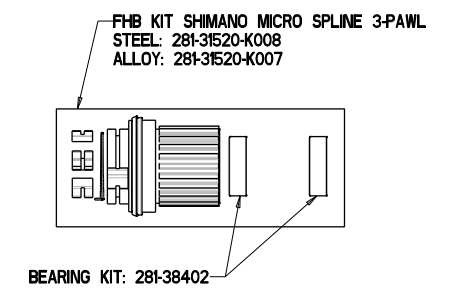
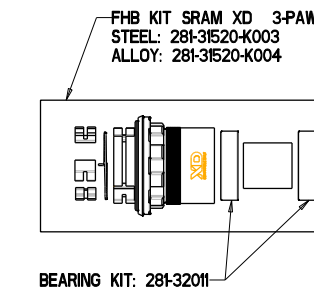
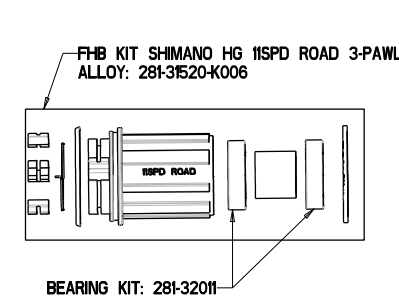
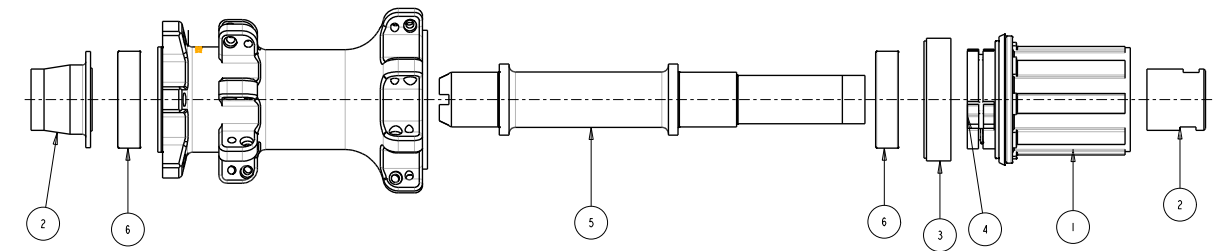



# SRX-CL REAR EXPLODED VIEW

	Description	Part #
1	SRC/SRX FH Body Kit HG Steel 3 Pawl	281-31520-K001
	SRC/SRX FH Body Kit HG Alloy 3 Pawl	281-31520-K002
	SRC/SRX FH Body Kit XD Steel 3 Pawl	281-31520-K003
	SRC/SRX FH Body Kit XD Alloy 3 Pawl	281-31520-K004
	SRC/SRX FH Body Kit HG 11R Alloy 3 Pawl	281-31520-K006
	SRC/SRX FH Body Kit MS Alloy 3 Pawl	281-31520-K007
	SRC/SRX FH Body Kit MS Steel 3 Pawl	281-31520-K008
	SRC/SRX FH Body Kit XDR Alloy 3 Pawl	281-31520-K013
	SRC/SRX FH Body kit Campy N3W Al 3 pawl	281-31520-K016
2	SRX CL Rear 12mm HG End Cap Kit	281-31519-K014
	SRX CL Rear 12mm XD End Cap Kit	281-31519-K015
	SRX CL Rear 12mm MS End Cap Kit	281-31519-K016
	SRX CL Rear QR HG End Cap Kit	281-31519-K020
	SRX CL Rear QR XD End Cap Kit	281-31519-K021
	SRX CL Rear 12mm Campy N3W End Cap Kit	281-31519-K023
3	SRC/SRX Ratchet Ring Kit	281-32014
4	SRC/SRX Pawl/Spring Kit 3 Pawl	281-31620
5	SRX CL Rear Axle Kit 148 Alloy	281-32013-K011
	SRX CL Rear Axle Kit 150/157 Alloy	281-32013-K012
	SRX CL Rear Axle Kit 148 Steel	281-32013-K013
	SRX CL Rear Axle Kit 150/157 Steel	281-32013-K014
	SRX CL Rear Axle 135/142 Kit Alloy	281-32013-K015
	SRX CL Rear Axle 135/142 Kit Steel	281-32013-K016
6	SRX CL Rear Bearing 6903/63803-D2 Kit	281-38692
7	SRC/SRX 6902 Bearing (28x15x7) Kit Qty 2	281-32011
8	SRC/SRX 63802 Bearing (24x15x7) Kit Qty 3	281-38402

# SRX-CL REAR EXPLODED VIEW

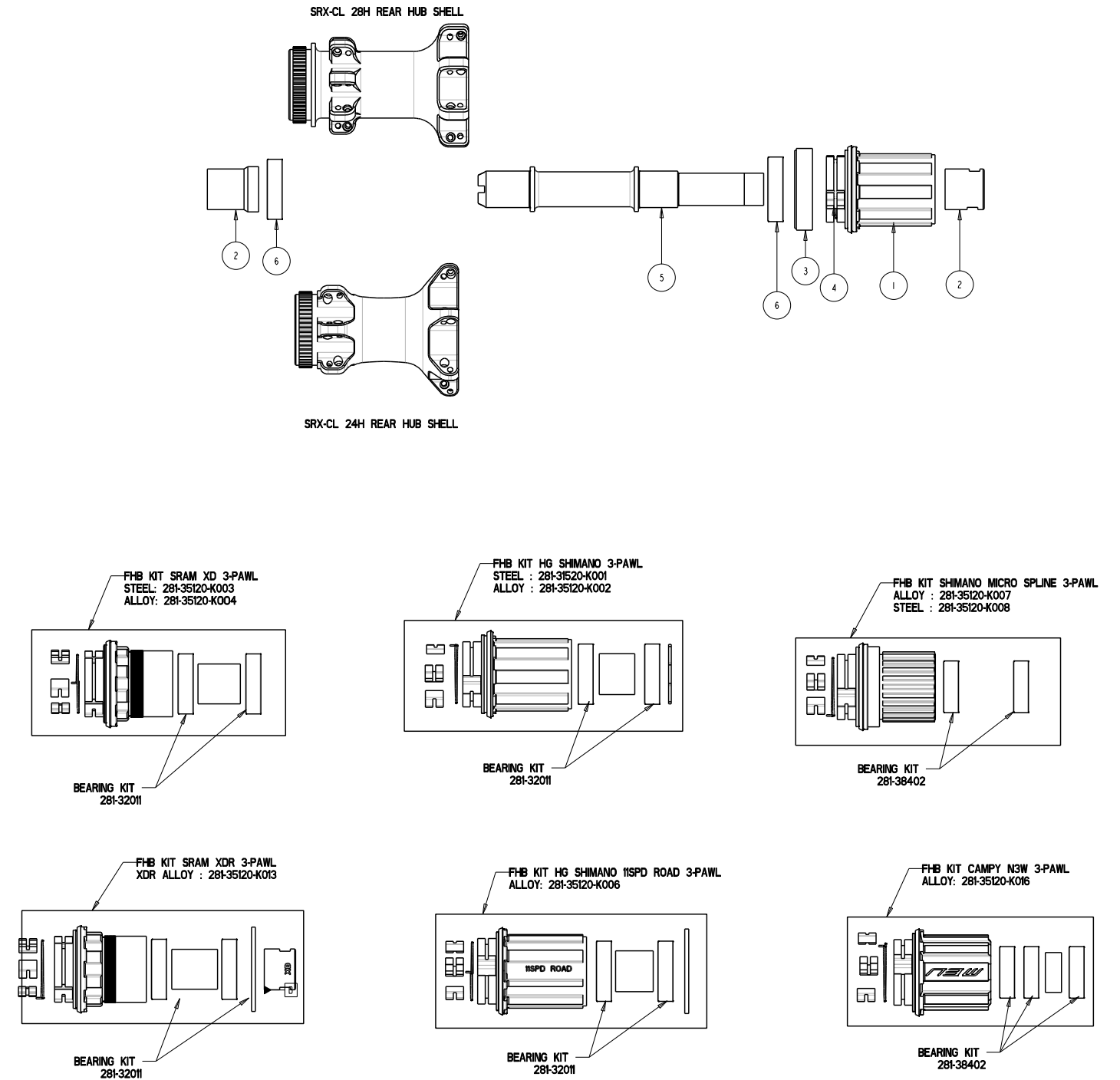

## GLOBAL HEADQUARTERS & HAYES BICYCLE GROUP USA

5800 W. Donges Bay Rd.  
Mequon, WI 53092

## HAYES BICYCLE GROUP EU

Dirnismaning 20 a  
85748 Garching (b. Munich)  
Germany

## HAYES BICYCLE GROUP ASIA

16F, No. 37, Sec. 3  
Mincyuan E. Rd.  
Zhongshan District

[facebook.com/SunRingle](https://facebook.com/SunRingle)



[instagram.com/SunRingleWheels](https://instagram.com/SunRingleWheels)



#100PercentTrue

HAYES

*m*  
manitou

PROTAPER

  
REYNOLDS

  
SUN  
ringle

  
WHEELSMITH  
SPOKES

HAYESBICYCLE.COM

 HAYES  
PERFORMANCE SYSTEMS