

DORADO

DORADO COMP 37MM SERVICE GUIDE



MANITOU

5800 W Donges Bay Rd
Mequon, WI 53092

manitoumtb.com

888.686.3472

Support: manitoumtb.com/support

WARRANTY

For full warranty information please
visit hayesbicycle.com/warranty

HAYES

manitou

PROTAPER

REYNOLDS

SUN
ringle

INTRODUCTION

This manual is intended to guide the user through basic service of Manitou Dorado Comp 37mm front forks. We highly suggest the service on these forks be performed by an experienced suspension mechanic. Service is supported by the identification of common parts and assemblies that have been assembled into Service Kits. The purpose of this manual will be to describe conditions that may drive the need for service and to provide installation instructions for the kits.

Please read through the manual carefully before beginning the service of your fork. Having a basic understanding of the tasks you are about to perform will assist you greatly in the disassembly and re-assembly of your fork.

Please read through the required tools page and be sure you have all of the items you will need for the service of your fork. The 50 hour service only requires the dust wiper seals and lubricants to be replaced. The complete 200 hour service requires all O-rings and seals shown in this guide to be replaced.

For any assistance with the service of your Dorado Comp please contact our Technical Service Department at 888-686-3472 and email them at techsupport@hayesbicycle.com.

⚠ WARNING ⚠

We highly recommend that service be performed by a certified bicycle mechanic. Failure to follow instructions presented in this manual could lead to serious injury or death. Any questions about the servicing of this fork or the manual itself should be directed to Hayes Customer Support at:

Hayes Bicycle USA	5800 W Donges Bay Road Mequon WI 53092
	Phone: 888.686.3472
	Email: techsupport@hayesbicycle.com

Hayes Bicycle Europe	Dirnismaning 20 a 85748 Garching (b. Munich) Germany
	Phone: +49 89 203237450
	Email: techsupportEU@hayesbicycle.com

Hayes Bicycle Asia	16F, No. 37, Sec. 3 Mincyuan E. Rd. Zhongshan District Taipei City 10476 Taiwan ROC
	Phone: 886-2-2518-1108

TABLE OF CONTENTS

SECTION	PAGE NUMBER
Tools And Materials	5
Damping Leg Service Disassembly	6
Damping Leg Service Assembly	9
Spring Leg Service Disassembly	12
Spring Leg Service Assembly	15
Dust & Oil Seal Replacement	18
Exploded View, Parts List, & Torque Table	20
O-Ring Placement Diagram & Table	23

TOOLS AND MATERIALS

Below is a list of tools that will be used in the complete service of a Dorado fork:

- Dorado Complete Rebuild Kit – Manitou Part number 141-38361-K001 (Needed for 200 hour complete service)
- Dorado 37mm Seal Kit - Manitou Part Number 141-38380-K019 (Needed for 50 hour basic service)
- Dorado Clamp Blocks – Manitou Part Number 172-31464
- 34mm and 37mm Seal Press – Manitou Part Number 172-37540-K002
- 5wt Maxima Fork oil - Manitou part number 85-0023
- Manitou 5w40 Semi-Bath Oil - Manitou part number 85-0022
- Slickoleum™ Grease - Manitou part number 141-33604-K001
- Torque Wrench
- 12mm Combination Wrench
- 13mm Combination Wrench
- 22mm Combination Wrench
- 32mm Crow’s Foot
- 2mm Allen Wrench
- 2.5mm Allen Wrench
- 5mm Allen Wrench
- 6mm Allen Wrench
- 24mm flat ground Socket with ratchet
- 26mm Socket
- 16 notch Bottom Bracket Tool
- Small Flat Blade Screwdriver
- Needle Nose Pliers
- Pick or similar tool for removing O-rings
- Blue Loctite

DAMPING LEG DISASSEMBLY

- 1 Using a 2mm Allen wrench, remove the ABS+ adjuster knob. Be sure you capture the 2 detent balls and springs under the knob.

NOTE: Be sure to hold the knob still while removing the screw. The damper adjuster may be damaged if the knob is over torqued.



- 2 Be sure you capture the 2 detent balls and springs under the knob.



- 3 First step is to loosen the damping leg top cap using a 16 notch Bottom Bracket Tool. It helps if the leg is still clamped in the lower crown assembly while breaking the top cap loose (be sure the upper crown is loosened, you only want the lower tightened when breaking loose the top cap). Only loosen the top cap at this point. Do not remove it.



DAMPING LEG DISASSEMBLY

- 4 Loosen the pinch bolts on the lower crown and remove the damping leg from the fork. You will need to remove the frame bumpers to do so. Put them in a safe place so you do not misplace them.

TIP: The ends of the Dorado sag guide can be used to spread the clamps apart and aid in leg removal.

- 5 Clamp the upper sleeve of the fork in bike stand.

- 6 Remove the top cap from the fork leg using a 16 notch Bottom Bracket Tool. The top cap is still attached to the rebound shaft at this point.

- 7 You will now remove the top cap from the rebound shaft. Place a 13mm wrench on the flats of the rebound shaft and use a 16 notch Bottom Bracket Tool to unthread the top cap from the shaft. Once the top cap is unthreaded, remove the rebound knob from the top cap.



- 8 Remove the fork leg from the bike stand and pour the oil out of the leg. Slide the inner leg out of the outer leg and leave the outer leg to drain in a drainage pan.



DAMPING LEG DISASSEMBLY

9 Holding the inner leg over a drainage pan, stroke the rebound shaft several times to drain the rest of the oil from the inner leg.

10 Wrap the inner leg in a rag and lightly clamp it into a bike stand with the rebound shaft pointing down towards the floor.

11 Remove the damping cartridge from the inner leg using a 24mm socket.



12 Pull the damping cartridge completely out of the inner leg.



DAMPING LEG DISASSEMBLY

13 Replace the following O-rings on the rebound damper assembly.

A. O-ring #100-012 - This is the O-ring above the threads on the end of the damper assembly.



B. O-ring # 100-026 - This is the O-ring that is around the outside of the compression assembly top cap.

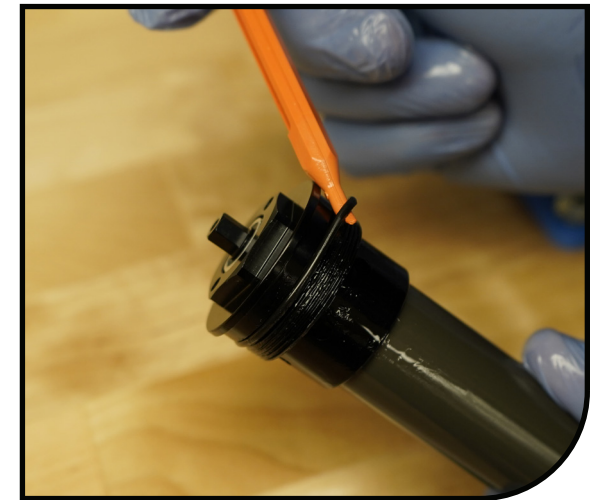

DAMPING LEG ASSEMBLY

- 1** Inspect the inner and outer damper tubes and be sure they are free from debris and contaminants. Put a small amount of Slickoleum Grease on the O-ring on the rebound end of the damper cartridge assembly. Install the assembly in the inner leg by sliding it into the bottom of the leg. Use a 26mm socket to tighten it into the leg. Tighten to 6.8-9 Nm (60-80 in lb).



- 2** Insert the detent springs into opposite holes in the end cap and place the detent balls on top of the springs. To hold the detent balls in place on the spring use a small dab of grease.



- 3** Install the ABS+ adjuster knob onto the end cap and secure with the 2mm screw.

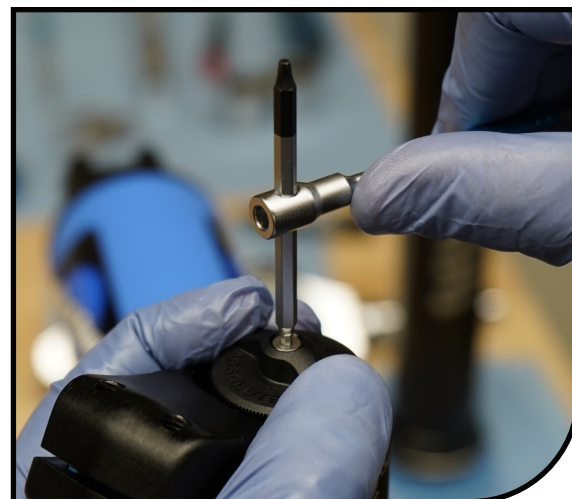

DAMPING LEG ASSEMBLY

- 4** Replace the oil and dust seals on the outer leg following the directions on pages 18-19. Inspect the inside of the outer leg and the outside of the inner leg and be sure they are free from debris and contaminants. Lube the oil seal and dust wiper on the outer leg with a small amount of Slickoleum grease. Slide the inner leg into the outer leg and clamp into the bike stand.

- 5** Replace O-ring # 100-027 on the top cap.

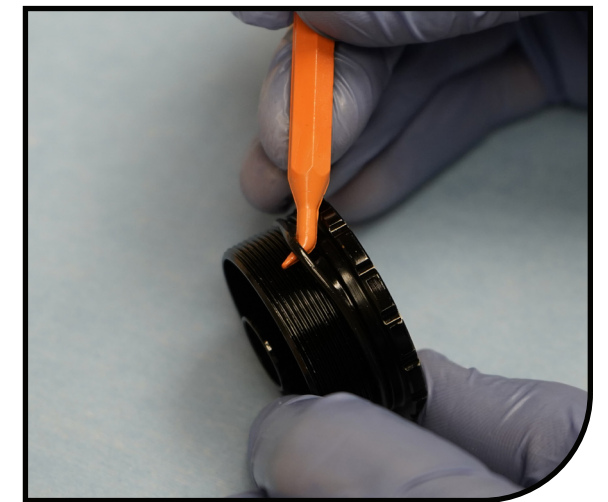

- 6** Install the top cap onto the end of the rebound shaft. Use a 16 notch Bottom Bracket Tool and a 12mm wrench to tighten to the proper torque of 6.8-9.0 N m (60-80 in lb).



DAMPING LEG ASSEMBLY

- 7 Install the rebound knob into the top cap by snapping it into place. Fully close the rebound by turning the knob clockwise.
- 8 Fully extend the rebound shaft, pulling the inner leg up into the outer leg.

- 9 Pour 320cc damper oil (5wt fork oil) into the leg. Stroke the rebound shaft to bleed the system and release the air. You want to stroke the rebound shaft a few times with the rebound fully closed, then turn the rebound knob open two clicks counterclockwise. Stroke the rebound shaft another 15-20 times and the system will be bled.



- 10 After damper is fully bled, fully extend the inner leg and tighten down the top cap using a 16 notch Bottom Bracket Tool to the proper torque of 6.8-9.0 N m (60-80 in lb).
- 11 Thoroughly clean leg assembly of all residual oil, then reinstall the damping leg into the fork crowns on the bike.

SPRING LEG DISASSEMBLY

- 1 **NOTICE**
IF CHANGING SPRING RATE WITHOUT SERVICE, ONLY STEPS 1 AND 2 FROM THIS SECTION ARE NECESSARY.
Using a 2mm hex wrench remove the preload adjuster on the bottom of the leg.
NOTE: Be sure to hold the knob still while removing the screw. The damper adjuster may be damaged if the knob is over torqued.



- 2 Using a 20mm socket loosen the bottom spring cap. Then gently remove the cap and spring by pulling them out of the leg.

NOTICE
For information of spring rate, see setup guide.



- 3 Loosen the pinch bolt on the top crown, and crack the top cap loose with a 16 notch Bottom Bracket Tool.



SPRING LEG DISASSEMBLY

- 4** Loosen the pinch bolts on the lower crown, and remove the leg from the fork. Be sure not to misplace the frame bumper that will need to come off the fork leg.

TIP: The ends of the Dorado sag guide can be used to spread the clamps apart and aid in leg removal.



- 5** Lightly clamp the fork leg in a bike stand. Remove the top cap from the leg with a 16 notch Bottom Bracket Tool. Remove the top cap from the compression rod with a 14mm wrench on the top of the compression rod and a 16 notch Bottom Bracket Tool.



- 6** Pour the fluid out of the leg, and slide the inner leg out of the outer leg. Remove the outer leg from the stand and let it sit above a drainage pan.

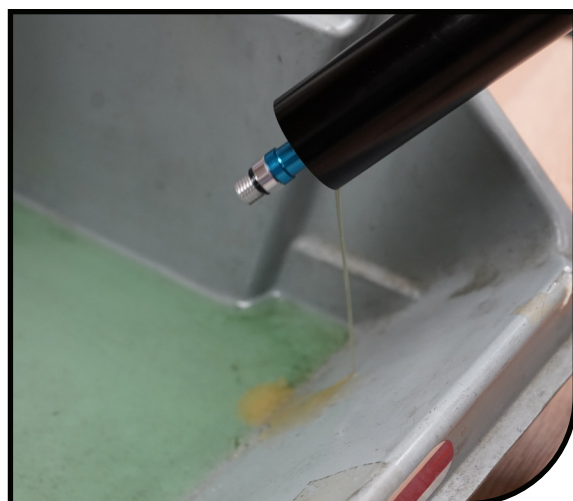

SPRING LEG DISASSEMBLY

- 7** Wrap the inner leg in a rag and clamp it lightly in the bike stand with the compression rod pointing towards the ceiling.

- 8** Loosen the Compression Rod Assembly from the inner leg with a 32mm wrench.



- 9** Remove Compression Rod Assembly from the inner leg.

SPRING LEG ASSEMBLY

NOTICE

IF CHANGING SPRING RATE WITHOUT SERVICE ONLY STEPS 1-4 FROM THIS SECTION ARE NECESSARY.

- 1 Inspect the inner leg, inside and out, clean it and be sure it is free from debris and contaminants. Lube the threads on inside of the inner leg, insert the compression rod, piston first, into the top of the inner leg using rotational motion.



- 2 Use a 32mm crows foot to tighten the bottom spring end cap to the proper torque of 1.8-2.8 N m (15-25 in lb).

- 3 Coat coil spring in grease. Gently insert it into the lower leg.

- 4 Use a 20mm socket to Install spring preload cap and torque to 6.8-9Nm {60-80In-lb}



SPRING LEG ASSEMBLY

- 5 Install preload knob, torque 2mm hex screw to .5-.7 Nm {4-6In-lb}.

- 6 Replace the oil and dust seals on the outer leg following the directions on page 19. Inspect the inside of the outer leg, and be sure it is free from debris and contaminants. Coat the inside of the seal with Slickoleum grease Slide the inner leg into the outer leg, and clamp the top of the outer leg in the bike stand.



- 7 Replace O-ring #100-027 on the top cap.

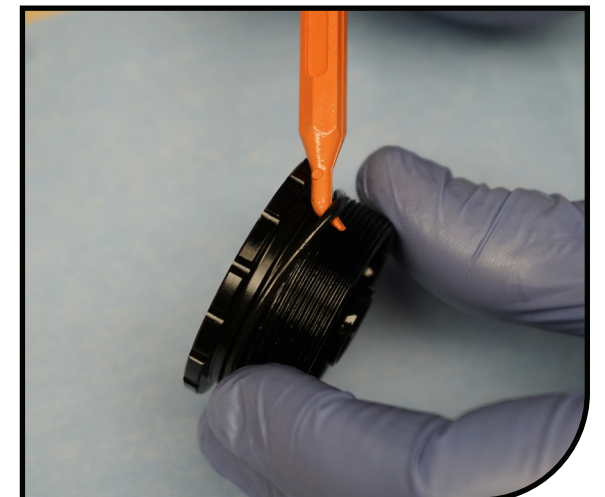

SPRING LEG ASSEMBLY

- 8** Install the top cap onto the end of the compression rod. Use a 16 notch Bottom Bracket Tool and a 13mm wrench to tighten to the proper torque of 3.4-4.5 N m (30-40 in lb). Add 30-40cc of semi bath into the outer leg.

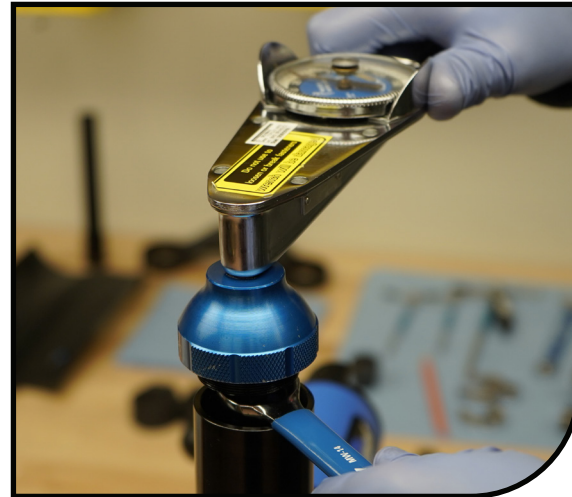

- 9** Install top cap into the outerleg. Using a 16 notch bottom bracket tool tighten to 6.8-9Nm {60-80 In-Lb}.



- 10** Using the sag guide tool to spread the crowns, slide the leg into the crown, align to proper wheel size and tighten crown bolts to 10.7-12.4 Nm {95-110 In-Lb}.

DUST & OIL SEAL REPLACEMENT

- 1** Using a pick or small blade screwdriver remove the wear ring from the outer leg.

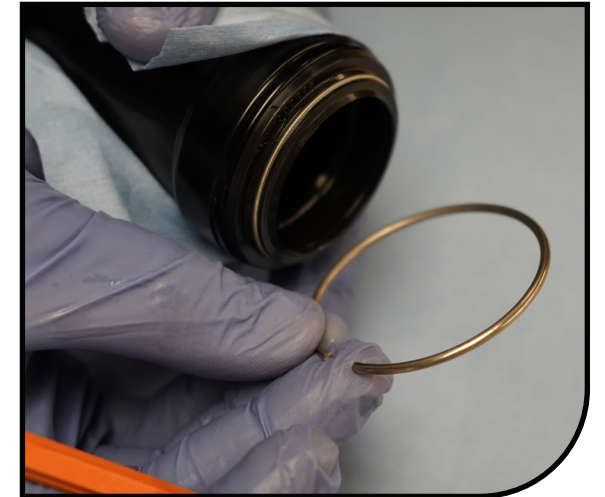

- 2** Gently pry out the old dust seal from the outer leg. A tool we have found that works well is a downhill tire lever. If using a flat blade screwdriver to remove the seal be careful the tip of the blade does not catch on the lip inside the outer leg.



- 3** Remove the foam ring. Clean seal bore and bushing thoroughly.

- 4** Soak new foam in Manitou bath oil. Place foam ring in the bottom of the seal bore.

DUST & OIL SEAL REPLACEMENT

- 5 Place the new dust seal into the leg and use the 37mm end of the seal press to press it completely into the leg.



- 6 Install the wear ring back onto the outer leg.

DORADO COMP EXPLODED VIEW

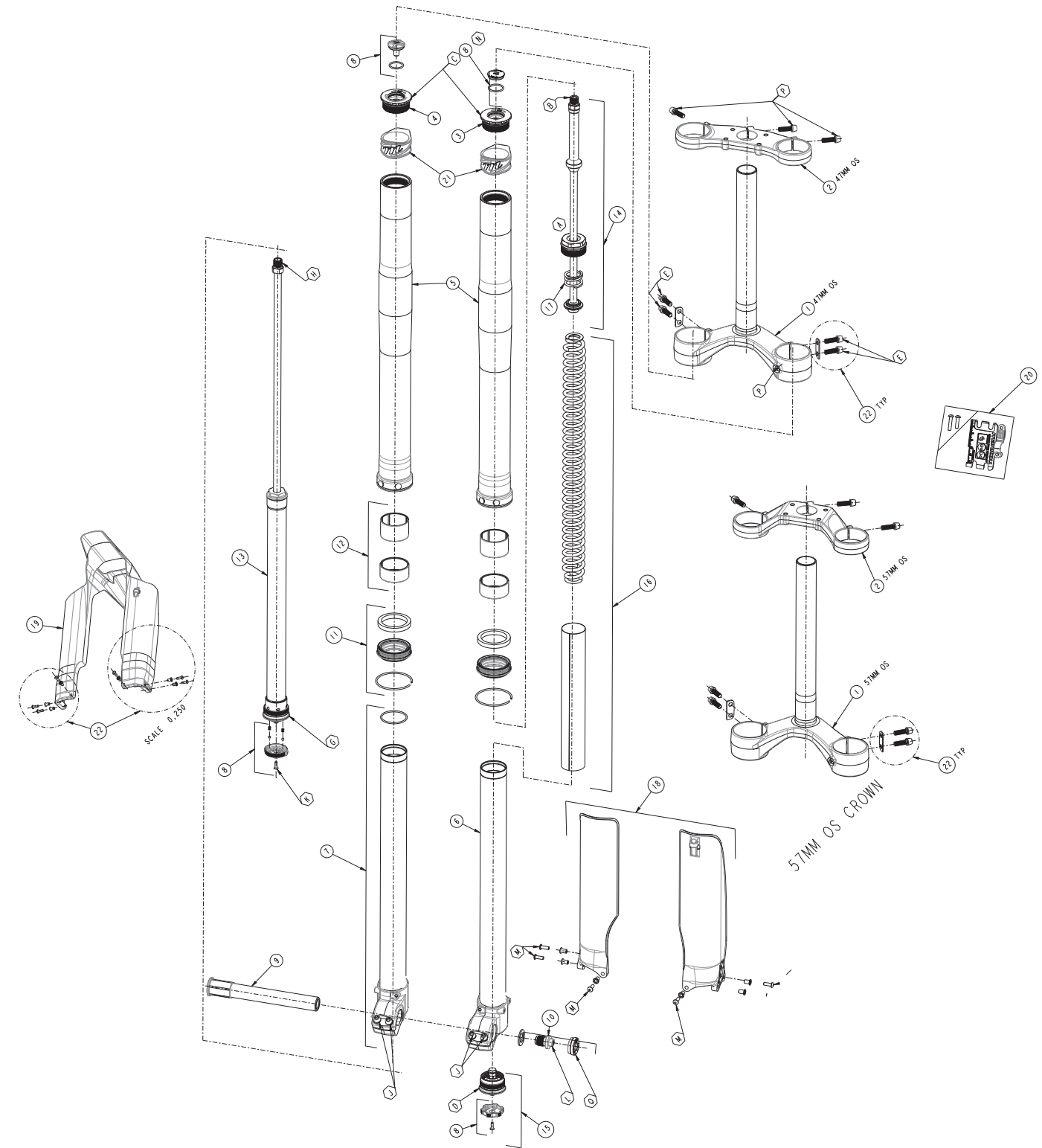

SERVICE KIT LIST (REFERNCE EXPLODED VIEW)

SERVICE KIT LIST, DORADO COMP 27.5"/29"			
ITEM	KIT DESCRIPTION	PART NUMBER	QTY
1	KIT, LOWER CROWN/STEER ASSEMBLY 47MM OS(INCL. PINCH BOLTS AND CLAMP SHIMS)	141-38380-K001	1
	KIT, LOWER CROWN/STEER ASSEMBLY 57MM OS(INCL. PINCH BOLTS AND CLAMP SHIMS)	141-38380-K002	1
2	KIT, UPPER CROWN, SHORT 47MM OS (INCL. PINCH BOLTS)	141-38380-K003	1
	KIT, UPPER CROWN, TALL 57MM OS (INCL. PINCH BOLTS)	141-38380-K004	1
3	KIT, DORADO 37MM TOP CAP COIL W-BLEED SCREW	141-38380-K035	1
4	KIT, DORADO 37MM TOP CAP REBND W-BLEED SCREW	141-38380-K036	1
5	KIT, OUTER LEG AL DORADO EXP/COMP 27.5"	141-38380-K012	2
6	KIT, LOWER LEG BRAKE SIDE SPRING INNER (INCL HARDWARE)	141-38380-K014	1
7	KIT, LOWER LEG DRIVE SIDE DAMPER INNER (INCL HARDWARE)	141-38380-K034	1
8	KIT, KNOBS, DORADO 37MM COMP	141-38380-K017	1
9	KIT, AXLE, HEXLOCK 20MM (NO HARDWARE)	141-30694-K008	1
10	KIT, AXLE HARDWARE, HEXLOCK 20MM	141-30694-K009	1
11	KIT, SEALS, 37MM	141-38380-K019	1
12	KIT, BUSHINGS 37MM	141-38380-K020	1
13	KIT, DAMPER ASSY DORADO COMP 27.5"/29"	141-38380-K023	1
14	KIT, DORADO 37MM COMP COMP ROD W-CVR	141-38380-K024	1
15	KIT, DORADO 37MM COMP PRELOAD ADJUST	141-38380-K025	1
16	KIT, DORADO 37MM COMP SPRING KIT X-SOFT 25 LB/IN		
	KIT, DORADO 37MM COMP SPRING KIT SOFT 30 LB/IN	141-38380-K026	1
	KIT, DORADO 37MM COMP SPRING KIT MEDIUM 35 LB/IN	141-38380-K029	1
	KIT, DORADO 37MM COMP SPRING KIT FIRM 40 LB/IN	141-38380-K030	1
	KIT, DORADO 37MM COMP SPRING KIT X-FIRM 45 LB/IN	141-38380-K031	1
	KIT, DORADO 37MM COMP SPRING KIT XX-FIRM 52.5 LB/IN	141-38380-K032	1
17	KIT, DORADO 37MM COMP TOP OUT SPRING	141-38380-K027	1
18	KIT, LEG GUARDS, DORADO (INCL. HARDWARE)	141-28073-K003	1
19	KIT, DORADO FENDER, 27.5" (INCL. HARDWARE)	141-30694-K011	1
	KIT, DORADO FENDER, 29" (OPTION, INCL. HARDWARE)	141-30694-K012	1
20	KIT, HOSE/SAG GUIDE, DORADO	141-38380-K043	1
21	KIT, FRAME BUMPERS, DORADO	141-24116	1
22	KIT, DORADO AUX FASTENER (INCL. PINCH BOLTS & CLAMP SHIMS FOR COMPLETE FORK)	141-38380-K028	1
REF	KIT, DECALS, DORADO EXP/COMP 27.5/29"	141-38380-K033	1
REF	KIT, MY21 DORADO REBUILD	141-38361-K001	1

TORQUE TABLE (REFERENCE EXPLODED VIEW)

TORQUE & THREADLOCKER TABLE "A"				
ITEM	TORQUE	THREADLOCK	APPLICATION	TOOL INTERFACE
A	1,7-2,8 Nm [15-25 LB-IN]	NONE	AIR SPRING LEG END CAP	22mm OPEN WRENCH
B	3,4-4,5 Nm [30-40 LB-IN]	NONE	SPRING SHAFT	13mm OPEN WRENCH
C	6,8-9,0 Nm [60-80 LB-IN]	NONE	TOP CAPS	16-NOTCHx44mm BOTTOM BRACKET TOOL
D	6,8-9,0 Nm [60-80 LB-IN]	NONE	PRELOAD ADJUSTER	20mm HEX SOCKET
E	10,7-12,4 Nm [95-110 LB-IN]	PATCH	CROWN PINCH BOLTS	5mm HEX KEY
G	6,8-9,0 Nm [60-80 LB-IN]	NONE	REBOUND CARTRIDGE	26mm HEX SOCKET
H	3,4-4,5 Nm [30-40 LB-IN]	NONE	REBOUND CARTRIDGE SHAFT	12mm OPEN WRENCH
J	10,7-12,4 Nm [95-110 LB-IN]	PATCH	DROPOUT PINCH BOLTS	5mm HEX KEY
K	0,5-0,7 Nm [4-6 LB-IN]	NONE	KNOB SCREW	2mm HEX KEY
L	12,0-15,0 Nm [106-133 LB-IN]	NONE	AXLE TENSION BOLT (WITH WHEEL INSTALLED)	5mm HEX KEY
M	0,5-0,7 Nm [4-6 LB-IN]	050525 (BLUE)	LEG GUARD SCREWS	2.5mm HEX KEY
N	HAND TIGHT	NONE	SCHRADER CAP	NONE
P	0,5-0,7 Nm [4-6 LB-IN]	NONE	CABLE GUIDE SCREW	2.5mm HEX KEY
Q	9,0-12,0 Nm [80-106 LB-IN]	PATCH	AXLE BOLT RETAINER	MANITOU TOOL P/N 172-34010

O-RINGDIAMGRAM

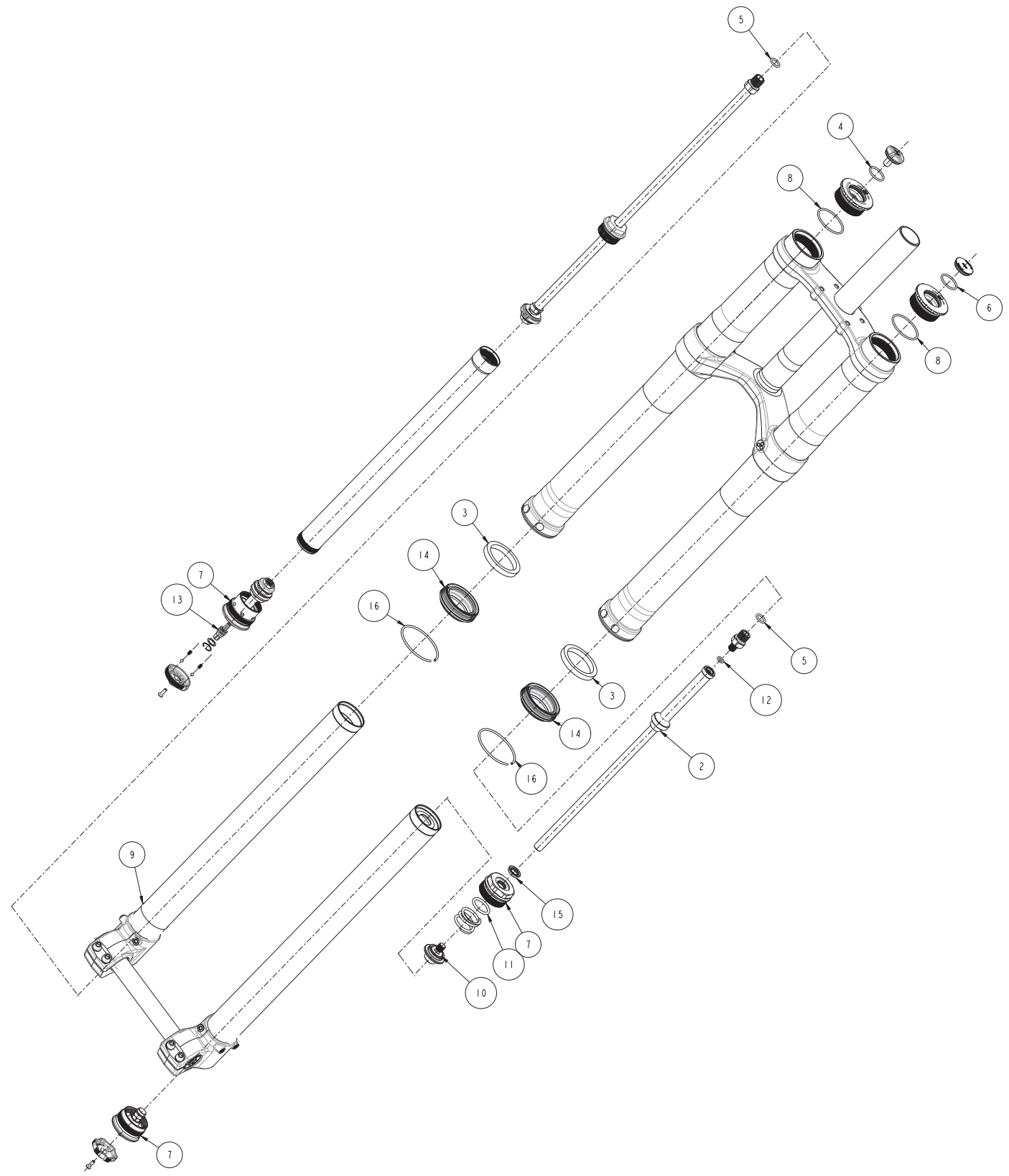

O-RINGCHART (USE DIAGRAMFOR REFERENCE)

141-38361-K001, MY21 DORADO REBUILD KIT

ITEM	PART NUMBER	DESCRIPTION	QTY
1	050516	BAG, 9" CLEAR POLY TUBE, 4MIL	1
2	09-23482	BUMPER, BTM-OUT 10MM	1
3	09-35761	FOAM INSERT, 37mm	2
4	08-29433-L017	O-RING, 2-SIZE, AS568A-	1
5	100-012	O-RING, 2-SIZE, AS568A-012	2
6	100-018	O-RING, 2-SIZE, AS568A-018	1
7	100-026	O-RING, 2-SIZE, AS568A-026	3
8	100-027	O-RING, 2-SIZE, AS568A-027	2
9	100-028	O-RING, 2-SIZE, AS568A-028	1
10	100-110	O-RING, 2-SIZE, AS568A-110	1
11	100-116	O-RING, 2-SIZE, AS568A-116	1
12	101-600-150	O-RING, METRIC	1
13	110-010	QUAD RING Q4-010	1
14	08-37487	SEAL, 37MM, IPC NBR, TSS	2
15	08-28921-L100	SEAL, U-CUP ROD	1
16	068821	WEAR RING 50MM	2

GLOBAL HEADQUARTERS & HAYES BICYCLE GROUP USA

5800 W. Donges Bay Rd.
Mequon, WI 53092

HAYES BICYCLE GROUP EU

Dirnismaning 20 a
85748 Garching (b. Munich)
Germany

HAYES BICYCLE GROUP ASIA

16F, No. 37, Sec. 3
Mincyuan E. Rd.
Zhongshan District

facebook.com/ManitouMTB



instagram.com/ManitouMTB



[#ScienceofSmooth](https://twitter.com/ScienceofSmooth)



HAYESBICYCLE.COM

